

---

### 3. EVAPORATION

Evaporation occurs when water is converted into water vapor at the evaporating surface, the contact between water body and overlapping air. At the evaporative surface, there is a continuous exchange of liquid water molecule into water vapor & vice versa.

The two main factors influencing evaporation from an open water surface are the supply of energy to provide the *latent heat of vaporization*, and the ability to transport the vapor away from the evaporative surface. The latent heat of vaporization  $l_v$  is the amount of heat absorbed by a unit mass of a substance. Solar radiation is the main source of heat energy.

The magnitude of annual evaporation is highly dependent on the prevailing climate in and around the water body. Evaporation has significant impact on water resources development especially in arid and semi-arid regions. Evaporation from Lake Nasser in Egypt (arid region) is about 3000 mm/year, where as evaporation from Lake Koka is about 1500 mm/year, which is half of that from Lake Nasser.

Evaporation rate is a function of several meteorological and environmental factors such as net radiation, saturation vapor pressure, actual vapor pressure of air, air and water surface temperature, wind velocity and atmospheric pressure. Section 3.1 discusses definition and measurements of these variables.

#### 3.1 Definition of some meteorological variables

The atmosphere forms a distinctive, protective layer about 100 km thick around the Earth. To the hydrologist, the troposphere (the first 11 km) is the most important layer because it contains 75% of the weight of the atmosphere and virtually all its moisture. On average, the temperature from ground level to the tropopause falls steadily with increasing altitude at the rate of 6.5 °C /km. This is known as the **lapse rate**.

Evaporation at high altitudes is promoted due to low atmospheric pressure as expressed in the psychrometric constant. The effect is, however, small and in the calculation procedures, the average value for a location is sufficient. A simplification of the ideal gas law, assuming 20°C for a standard atmosphere, can be employed to calculate atmospheric pressure P:

$$P = 101.3 \left( \frac{293 - 0.0065z}{293} \right)^{5.26} \quad (3.1)$$

where:

P atmospheric pressure [kPa],  
z elevation above sea level [m],

The psychrometric constant,  $\gamma$ , is given by:

$$\gamma = \frac{c_p P}{\varepsilon \lambda} = 0.665 \times 10^{-3} P \quad (3.2)$$

where

$\gamma$  = Psychrometric constant [kPa °C<sup>-1</sup>],  
P = Atmospheric pressure [kPa],  
 $\lambda$  = Latent heat of vaporization, 2.45 [MJ kg<sup>-1</sup>],  
 $c_p$  = Specific heat at constant pressure, 1.013 10<sup>-3</sup> [MJ kg<sup>-1</sup> °C<sup>-1</sup>], and  
 $\varepsilon$  = ratio molecular weight of water vapour / dry air = 0.622.

The specific heat at constant pressure is the amount of energy required to increase the temperature of a unit mass of air by one degree at constant pressure. Its value depends on the composition of the air, i.e., on its humidity. For average atmospheric conditions a value  $c_p = 1.013 \times 10^{-3}$  [MJ kg<sup>-1</sup> °C<sup>-1</sup>] can be used as an average atmospheric pressure is used for each location.

**Air density:** air density of moist air (kg/m<sup>3</sup>) is estimated by  $\rho_a = 3.486 (p/(273 + T))$  where  $p$  is the atmospheric pressure in kPa and  $T$  is air temperature in degrees Celsius.

**Water vapor:** the amount of water vapor in the atmosphere is directly related to the temperature. The water vapor content or humidity of air is usually measured as a *vapor pressure*, and the units used is millibar (mb).

**Specific humidity:** The mass of water vapor per unit mass of moist air is called specific humidity  $q_v$  and equals the ratio of the densities of water vapor  $\rho_v$  and of moist air  $\rho_a$

$$q_v = \frac{\rho_v}{\rho_a} \quad (3.3)$$

**Vapor pressure:** Dalton's law of partial pressures states that the pressure exerted by a gas (its vapor pressure) is independent of the pressure of other gases; the vapor pressure  $e$  of the water vapor is given by the ideal gas law as

$$e = \rho_v R_v T \quad (3.4)$$

where  $T$  is the absolute temperature in  $K$  and  $R_v$  is the gas constant for water vapor. If the total pressure exerted by the moist air is  $p$ , then  $p - e$  is the partial pressure due to the dry air, and

$$p - e = \rho_d R_d T \quad (3.5)$$

$$\rho_a = \rho_d + \rho_v \quad (3.6)$$

The gas constant for water vapor is

$$R_v = \frac{R_d}{0.622} \quad (3.7)$$

where 0.622 is the ratio of the molecular weight of water vapor to the average molecular weight of dry air.

Combining Eqs.(3.4), (3.5.) and (3.7) we get

$$p = \left( \rho_d + \frac{\rho_v}{0.622} \right) R_d T \quad (3.8)$$

The specific humidity  $q_v$  is approximated by

$$q_v = 0.622 \frac{e}{p} \quad (3.9)$$

where  $p = \rho_a R_a T$

The relationship between the gas constants for moist air and dry air is given by

$$R_a = R_d (1 + 0.608 q_v), \quad R_d = 287 \text{ J/Kg.K} \quad (3.10)$$

**Saturation vapor pressure  $e_s$**  : For a given air temperature, there is a maximum moisture content the air can hold and the corresponding vapor pressure is called *saturation vapor pressure  $e_s$*  . At this vapor pressure, the rates of evaporation and condensation are equal.

Over a water surface the saturation vapor pressure is related to the air temperature with equation

$$e_s = 611 \exp \left( 17.27 \frac{T}{237.3 + T} \right) \quad (3.11)$$

Where  $e_s$  is in Pascal (Pa = N/m<sup>2</sup>) and  $T$  is air temperature in degree Celsius.

Due to the non-linearity of the above equation, the mean saturation vapour pressure for a day, week, decade or month should be computed as the mean

between the saturation vapour pressure at the mean daily maximum and minimum air temperatures for that period. That is

$$e_s = \frac{e^{\circ}(T_{\max}) + e^{\circ}(T_{\min})}{2} \quad (3.12)$$

Using mean air temperature instead of daily minimum and maximum temperatures results in lower estimates for the mean saturation vapour pressure. The corresponding vapour pressure deficit (a parameter expressing the evaporating power of the atmosphere) will also be smaller and the result will be some underestimation of the reference crop evapotranspiration. Therefore, the mean saturation vapour pressure should be calculated as the mean between the saturation vapour pressure at both the daily maximum and minimum air temperature.

**The relative humidity  $R_h$ :** It is ratio of actual vapor pressure to its saturation value at a given air temperature  $T$  and is given by

$$R_h = \frac{e}{e_s} \quad (3.13)$$

**Dew-point temperature  $T_d$ :** The dew-point temperature  $T_d$  is the temperature at which space becomes saturated when air is cooled under constant pressure and with constant water-vapor content. It is the temperature having a saturation vapor pressure  $e_s$  equals to the existing vapor pressure  $e$ . Wet bulb thermometer measures the dew point temperature.

Saturation deficit is the difference between the saturation vapor pressure at air temperature  $e_s$  and the actual vapor pressure represented by the saturation vapor pressure at  $T_d$  which is the amount of water vapor in the air. The saturation deficit ( $e_s - e$ ) represents the further amount of water vapor that the air can hold at the temperature  $T_a$  before becoming saturated.

**Figure 3.1** Saturated vapor pressure as a function of temperature over water. Point C has vapor pressure  $e$  and temperature  $T$ , for which the saturated vapor pressure is  $e_s$ . The temperature at which the air is saturated for vapor pressure  $e$  is the dew-point temperature  $T_d$ .

Figure 3.1 shows the saturation vapor pressure curve and the  $T_d$  and  $T$ ,  $e_s$  and  $e$  relationship. If the barometric pressure is kept constant and the temperature is reduced, i.e. if the air is cooled at constant barometric pressure, a stage will come when the air will become saturated with the same amount of vapor. If the cooling is continued, the vapor will get condensed on the contact surfaces. This condensation will be in the form of dew if the dew point is  $> 0^\circ\text{C}$ ; and it will be in the form of frost if the dew point is  $< 0^\circ\text{C}$ .

**Example 3.1** At a climatic station, air pressure is measured as 100 kPa, air temperature as  $20^\circ\text{C}$ , and the wet-bulb, or dew-point, temperature as  $16^\circ\text{C}$ . Calculate the corresponding vapor pressure, relative humidity, specific humidity, and air density.

**Solution:** The saturated vapor pressure at  $T = 20^\circ\text{C}$  is given by

$$e_s = 611 \exp\left(17.27 \frac{T}{237.3 + T}\right)$$

$$e_s = 611 \exp\left(\frac{17.27 * 20}{237.3 + 20}\right)$$

$$= 2339 \text{ Pa}$$

and the actual vapor pressure  $e$  and the relative humidity are calculated using the dew-point temperature  $T_d=16$  °C

$$e = 611 \exp\left(\frac{17.27 * 16}{237.3 + 16}\right)$$

$$= 1819 \text{ Pa}$$

The relative humidity is  $= e/e_s$

$$= 1819 / 2339$$

$$= 0.78$$

$$q_v = 0.622 \frac{e}{p}$$

$$q_v = 0.622 \left(\frac{1819}{100000}\right)$$

$$= 0.01133 \frac{\text{kg of water}}{\text{kg moist air}}$$

$$= 78\%$$

The air density is calculated from the ideal gas law

$$\rho_a = \frac{p}{287(1 + 0.608 q_v)T(K)}$$

$$\rho_a = \frac{100000}{287(1 + 0.608 * .01133)293}$$

$$= 1.18 \text{ kg/m}^3$$

Note that the actual vapor pressure can be determined from the difference between the dry and wet bulb temperatures, the so-called wet bulb depression. The relationship is expressed by the following equation:

$$e_a = e^\circ(T_{wet}) - g_{psy}(T_{dry} - T_{wet}) \quad (3.14)$$

where

$e_a$  = Actual vapour pressure [kPa],

$e^\circ(T_{wet})$  = Saturation vapor pressure at wet bulb temperature [kPa],

$\gamma$  = Psychrometric constant [kPa °C<sup>-1</sup>],

$T_{dry} - T_{wet}$  = Wet bulb depression, with  $T_{dry}$  the dry bulb and  $T_{wet}$  the wet bulb temperature [°C].

The psychrometric constant of the instrument is given by:

$$g_{psy} = a_{psy} P \quad (3.15)$$

where  $a_{psy}$  is a coefficient depending on the type of ventilation of the wet bulb [°C<sup>-1</sup>], and  $P$  is the atmospheric pressure [kPa]. The coefficient  $a_{psy}$  depends mainly on the design of the psychrometer and rate of ventilation around the wet bulb. The following values are used:

$a_{psy} =$	0.000662	for ventilated (Asmann type) psychrometers, with an air movement of some 5 m/s,
	0.000800	for natural ventilated psychrometers (about 1 m/s),
	0.001200	for non-ventilated psychrometers installed indoors.



### 3.2 Measurements of some meteorological variables

A site for a meteorological station need to be level ground about 10 m by 7 m in extent covered by short grass and enclosed by open fencing or railings. The site should not have any steep slopes in the immediate vicinity and should not be located near trees or buildings. A recommended site plan for the instrument is shown in Fig. 3.2.

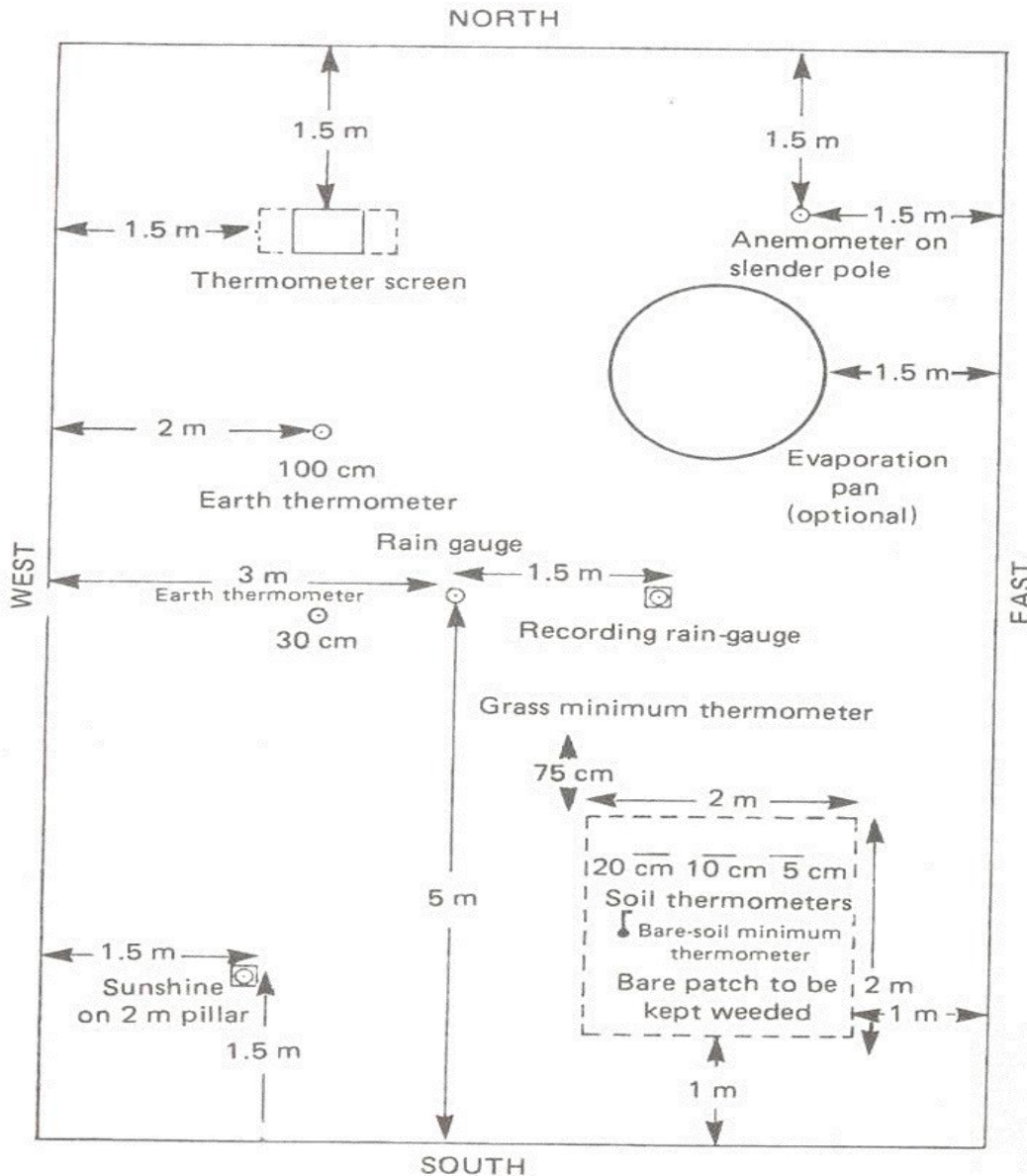

**Figure 3.2** Plan of a meteorological station for the northern hemisphere (Shaw, 1994)

### 3.2.1 Measurements of air and soil temperatures

In the ordinary Stevenson Screen, for example, two vertically hung thermometers are for direct reading of the air temperature (dry bulb) and the reading of the wet bulb, covered with muslin kept moist by a wick leading from a small reservoir of distilled water. With these two temperature readings the dew point, vapor pressure and relative humidity of the air are obtained. Supported horizontally are maximum and minimum thermometers. The four thermometers are read at 0800 A.M. each day and at this time the maximum and minimum thermometers are reset. Soil and ground/grass temperature measurements are often taken using soil and earth/grass thermometers.

The dry and wet bulb temperatures are measured using psychrometers. Most common are those using two mercury thermometers, one of them having the bulb covered with a wick saturated with distilled water, and which measures a temperature lowered due to the evaporative cooling. When they are naturally ventilated inside a shelter, problems can arise if air flow is not sufficient to maintain an appropriate evaporation rate and associated cooling. The Assmann psychrometer has a forced ventilation of the wet bulb and dry bulb thermometers.

The dry and wet bulb temperature can be measured by thermocouples or by thermistors, the so called thermocouple psychrometers and thermo sound psychrometers. These psychrometers are used in automatic weather stations and, when properly maintained and operated, provide very accurate measurements.

### 3.2.2 Sunshine recorder

A standard Campbell-Stockes sunshine recorder is shown in Fig. 3.3. The working principle is that the glass sphere focuses the Sun's rays on to a specially treated calibrated card where they burn a trace. The accumulated lengths of burnt trace gives a measure of the total length of bright sunshine in hours.

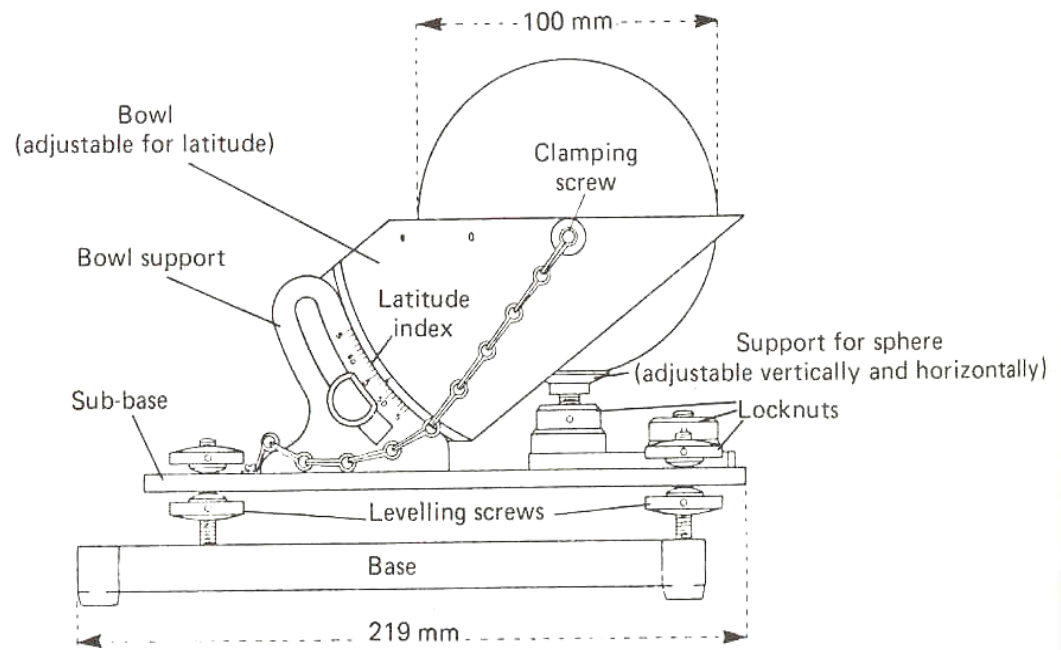

**Figure 3.3** Sunshine hour recorder Mk. 2 (Campbell - Stokes)

### 3.2.3 Wind speed and direction recorder

A cup anemometer is fixed on a 2 m long pole from the ground and the electrical recording apparatus is housed conveniently away from the installation. The cup anemometer can give instantaneous readings of wind velocity (m/s) or provide a run-of-the-wind a collective distance in km when the counter is read each day (Figure 3.4).

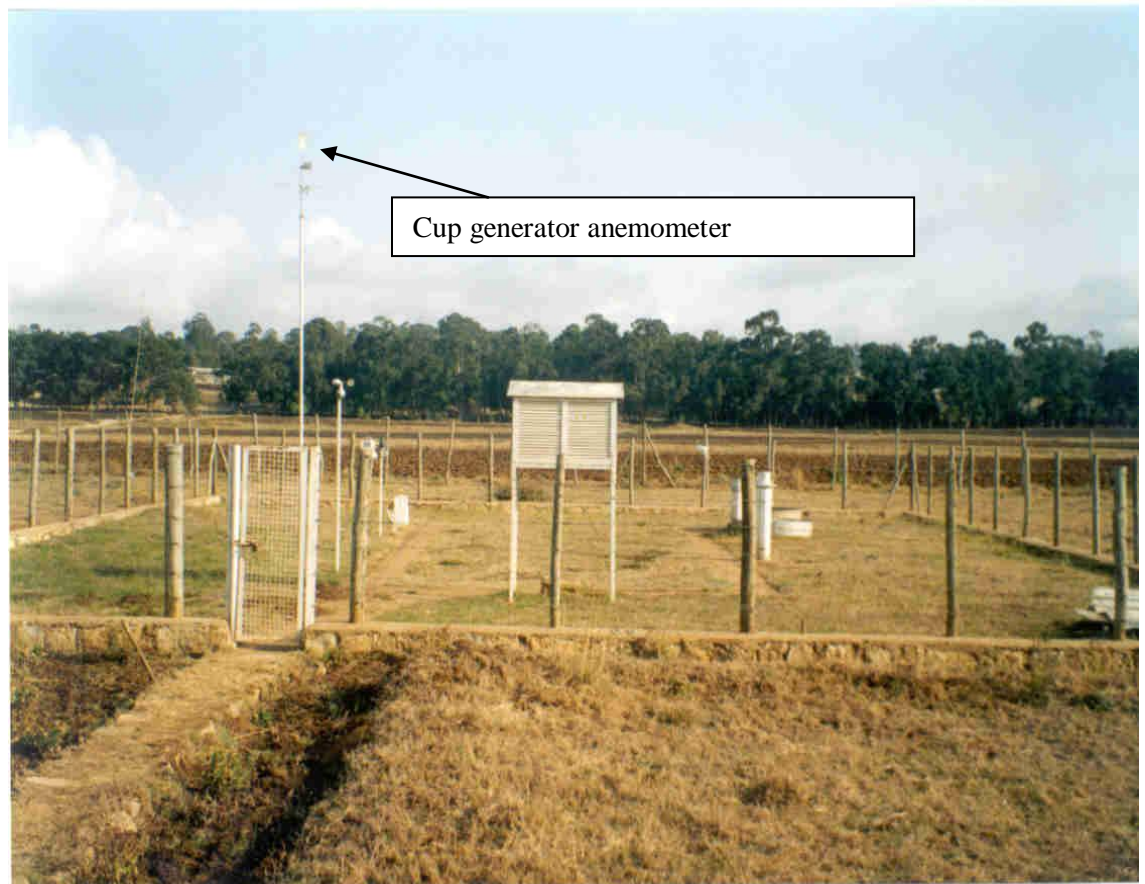

**Figure 3.4** NMSA 1<sup>st</sup> class meteorological station housed in the campus of the Alemaya University (Photo 2001).

Wind speeds measured at different heights above the soil surface are different. Surface friction tends to slow down wind passing over it. Wind speed is slowest at

the surface and increases with height. For this reason anemometers are placed at a chosen standard height, i.e., 10 m in meteorology and 2 or 3 m in agrometeorology. For the calculation of evapotranspiration, wind speed measured at 2 m above the surface is required. To adjust wind speed data obtained from instruments placed at elevations other than the standard height of 2m, a logarithmic wind speed profile may be used for measurements above a short grassed surface:

$$u_2 = u_z \frac{4.87}{\ln(67.8z - 5.42)} \quad (3.16)$$

where:

$u_2$  = wind speed at 2 m above ground surface [m/s],

$u_z$  = measured wind speed at  $z$  m above ground surface [m/s],

$z$  = height of measurement above ground surface [m].

Classes of mean monthly wind speed are (1) less than 1 m/s light wind, (2) between 1 and 3 m/s light to moderate wind, (3) from 3 to 5 m/s moderate to strong wind, and (4) above 5 m/s strong wind. Where no wind data are available within the region, a value of 2 m/s can be used as a temporary estimate. This value is the average over 2000 weather stations around the globe.

### 3.2.4. Dew point temperature measurement

Dew point temperature is often measured with a mirror like metallic surface that is artificially cooled. When dew forms on the surface, its temperature is sensed as  $T_{\text{dew}}$ . Other dew sensor systems use chemical or electric properties of certain materials that are altered when absorbing water vapour. Instruments for measuring dew point temperature require careful operation and maintenance and are seldom available in weather stations. The accuracy of estimation of the actual vapour pressure from  $T_{\text{dew}}$  is generally very high.

### 3.2.5 Measurement of evaporation and evapotranspiration

#### Pan evaporation measurement

A practical way to measure evaporation directly is by the use of an evaporation

pan. The pan exposes free water surface to the air, and the evaporation rate is determined by measuring the water loss during one time period, usually one day. Due to the difference in area of exposure and surrounding meteorological conditions, evaporation from lakes is less than from the one obtained from the pan measurement (with annual average multiplying factor about 0.7).

**The National Weather Service Class A** pan is recommended by the World Meteorological Organization as a standard instrument for evaporation measurements. The Class A pan is made of unpainted galvanized iron, has a diameter of 122 cm and a height of 25.4 cm and is mounted about 15 cm above the ground on supports which permit free flow of air around and under the pan (Figure 3.5).

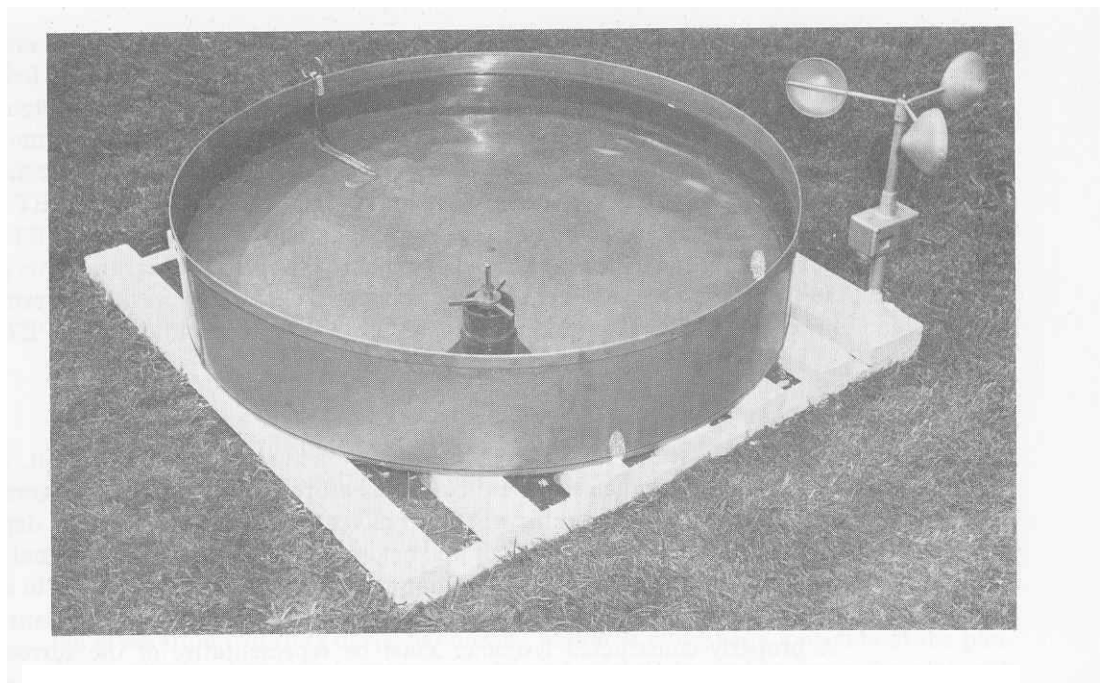

**Figure 3.5** Class A evaporation pan

Water loss is determined by daily measurements of water level using a micrometer hook gage installed in a stilling well set inside the pan. The pan is initially filled to a height of 20 cm and is refilled when the water level has fallen below 17.5 cm. Daily evaporation is computed as the difference between two

successive observations, corrected to account for any intervening precipitation measured in a nearby gage. An alternative procedure is to add a measured amount of water daily to bring the water level in the pan up to a fixed point in the stilling well. This procedure permits a more accurate measurement of water loss and assures that the pan has the proper water level at all times.

Little is known about the spatial variability of evaporation. For general purpose and preliminary evaporation estimates, a density of one station per 5000 km<sup>2</sup> appears to be sufficient.

**Indirect measurement of evapotranspiration based on water balances of watersheds and lakes:**

A basic water balance equation, which is applied over a particular time interval, is given by:

$$E = P - 1000 * (V_R - V_S + V_L) / A \quad (3.17)$$

Where:

$E$  = net evapotranspiration loss from the specified volume per unit area (mm)

$P$  = net precipitation (or irrigation) input to the specified volume per unit area (mm)

$V_R$  = net volume of liquid water entering or leaving the specified volume as measured inflow or outflow both above and below the surface (m<sup>3</sup>)

$V_S$  = change in liquid water stored within the specified volume (m<sup>3</sup>)

$V_L$  = "leakage," i.e., that total volume of liquid water leaving the specified volume which is not, or cannot be, measured, and which therefore represents an error in the method (m<sup>3</sup>)

$A$  = effective area of the sample volume at the land surface (m<sup>2</sup>)

River runoff is arguably the most accurate hydrologic measurement and is a valuable, direct determination of the available surface water resource. Careful gauging can provide stream-flow measurements accurate to about 2 %. Using carefully selected and well-managed paired watersheds can provide valuable and convincing evidence of the consequences of land-use change on evapotranspiration.

A systematic uncertainty in the evaporation loss deduced from a catchment water balance arises from the possibility that the unmeasured leakage forms a significant part of the total water balance.

**Lysimeters.** A lysimeter is a device in which a volume of soil, typically 0.5 to 2.0 m in diameter, which may be planted with vegetation, is isolated hydrologically so that leakage  $V_L = 0$  in Eq. (3.11). It either permits measurement of drainage  $V_R$  or makes it zero and, in the case of a weighing lysimeter, the change in water storage  $V_S$  is determined by weight difference. If evapotranspiration from the lysimeter is to be representative of the surrounding area, it should contain an undisturbed sample of the soil and vegetation.

### 3.3 Methods for estimating potential evaporation

**Potential Evaporation  $E_0$  (mm/day)** defined as the quantity of water evaporated per unit area, per unit time from an idealized extensive free water surface under existing atmospheric conditions. Potential Evaporation of a given area varies daily, and is following the variations of the weather.

The three common methods of estimating evaporation will be discussed herein: the energy balance method, the aerodynamic method, and the combination method.

#### 3.3.1 The energy balance method

This method is widely used for estimating the amount of evaporation from a large body of water such as lakes, reservoirs etc.

Consider an evaporation pan of a circular tank containing water, in which the rate of evaporation is measured by the rate of fall of the water surface ( $E_r = -dh/dt$ ). Based on the continuity and energy equation, one can derive the energy balance equation for evaporation as

$$E_r = \frac{1}{l_v \rho_w} (R_n - H_s - G) \quad (3.18)$$



If the sensible heat flux  $H_s$  (sensible heat loss to surroundings atmosphere to raise the temperature) and the ground heat flux  $G$  are both zero, then an evaporation rate  $E_r$  can be calculated as the rate at which all the incoming net radiation is

$$E_r = \frac{R_n}{l_v \rho_w} \quad (3.19)$$

absorbed by evaporation:

where  $l_v$  = latent heat of vaporization (J/kg), [ $l_v$  (kJ/kg) = 2500 - 2.36 T (°C) up to 40 °C]

$\rho_w$  = water density (kg/m<sup>3</sup>)

$R_n$  = net radiation (W/m<sup>2</sup>)

$E_r$  = rate of evaporation (m/s)

**Example 3.2** Calculate by the energy method the evaporation rate from an open water surface, if the net radiation is 200 W/m<sup>2</sup> and the air temperature is 25 °C, assuming no sensible heat or ground heat flux.

**Solution:** The latent heat of vaporization at 25 °C is  $l_v = 2500 - 2.36 * 25 = 2441$  kJ/kg. Density of water at 25 °C is 997 kg/m<sup>3</sup>

$$\begin{aligned} E_r &= \frac{R_n}{l_v \rho_w} \\ &= \frac{100}{2441 * 1000 * 997} \\ &= 8.22 * 10^{-8} \\ &= 8.22 * 10^{-8} * 1000 * 86400 \text{ mm/day} \\ &= 7.10 \text{ mm/day} \end{aligned}$$

### Net radiation estimation

Radiometer or actinometer measures radiant energy received by the ground. For most studies of evaporation, incident all-wave radiation data are adequate because

the reflectivity of water is nearly constant (average daily values of 5 and 3 %, short and long wave respectively).

The net radiation  $R_n$  is the net input of radiation at the surface at any instant. It is the difference between the radiation absorbed  $R_i(1 - \alpha)$  where  $R_i$  is the incident radiation, and that emitted  $R_e$ .

$$R_n = R_i(1 - \alpha) - R_e \quad (3.20)$$

$\alpha$  = albedo, it is the fraction of reflected radiation,  $\alpha$  for deep water bodies is about 0.08 because deep water bodies absorb most of the radiation they receive, and  $\alpha$  for grass land and a range of agricultural crops = 0.23. In contrast fresh snow reflects most of the incoming radiation with  $\alpha$  as high as 0.9, see Table 3.1.

**Table 3.1** Plausible values for daily mean short wave radiation reflection coefficient (Albedo)  $\alpha$  for broad land cover classes (Maidement, 1993)

Land cover class	Short-wave radiation Reflection coefficient $\alpha$
Open water	0.08
Tall forest	0.11 - 0.16
Tall farm crops (e.g., sugarcane)	0.15 - 0.20
Cereal crops (e.g., wheat)	0.20 - 0.26
Short farm crops (e.g. sugar beet)	0.20 - 0.26
Grass and pasture	0.20 - 0.26
Bare soil	0.10 wet - 0.35 dry

In the absence of measured solar radiation data, the total incoming short-wave radiation can in most cases be estimated from measured sunshine hours according to the following empirical relationship:

$$R_i = (0.35 + 0.61 \frac{n}{N}) S_o \quad (3.21)$$

Where:

$n/N$  = cloudiness fraction

$n$  = bright sunshine hours per day, h

$N$  = total day length, h

$S_o$  = extraterrestrial radiation, MJ m<sup>2</sup> day<sup>-1</sup> (Table 3.2)

**Table 3.2** Mean solar radiation for cloudless skies,  $S_o$  (MJm<sup>-2</sup> day<sup>-2</sup>)

Lat. Deg	Jan	Feb	Mar	Apr	May	Jun	Jul	Aug	Sept	Oct	Nov	Dec
0	28.18	29.18	30.02	28.47	26.92	26.25	26.67	27.76	29.60	29.60	28.47	26.80
10	25.25	26.63	29.43	29.60	29.60	29.31	29.43	28.76	29.60	28.05	25.83	24.41
20	21.65	25.00	28.18	30.14	31.40	31.82	31.53	30.14	28.47	25.83	22.48	20.50
30	17.46	21.65	25.96	29.85	32.11	33.20	32.66	30.44	26.67	22.48	18.30	16.04
40	12.27	17.04	22.90	28.34	32.11	33.49	32.66	29.18	23.73	18.42	13.52	10.76

*Net long-wave radiation.*- There is a significant exchange of radiation energy between the earth's surface and the atmosphere in the form of radiation at longer wave lengths, i.e., in the range 3 to 100 μm. Both the ground and the atmosphere emit black-body radiation with a spectrum characteristics of their temperature. Since the surface is on average warmer than the atmosphere, there is usually a net loss of energy as thermal radiation from the ground.

The exchange of long-wave radiation  $L_n$  between vegetation and soil on the one hand and atmosphere and clouds on the other, can be represented by the following radiation law:

$$L_n = L_i - L_o = -f\varepsilon\sigma T^4 \quad (3.22)$$

Where

$L_o$  = outgoing long-wave radiation (ground to atmosphere), MJm<sup>2</sup>day<sup>-1</sup>

$L_i$  = incoming long-wave radiation (atmosphere to ground), MJm<sup>2</sup>day<sup>-1</sup>

$f$  = adjustment for cloud cover

$\varepsilon$  = net emissivity between the atmosphere and the ground

$\sigma$  = the Stefan Boltzmann constant = 4.903x10<sup>-9</sup> MJ m<sup>-2</sup> day<sup>-1</sup> K<sup>-4</sup> = 5.67\*10<sup>-8</sup> W/m<sup>2</sup>.K<sup>4</sup>

$T$  = the absolute air temperature of the evaporating surface in degrees Kelvin (°C +273)

The net emissivity can be estimated from

$$\varepsilon = a + b\sqrt{e_d} \quad (3.23)$$

where:  $a$  and  $b$  = correlation coefficients,  $a$  lies in the range 0.34 to 0.44,  
and  $b$  in the range -0.14 to -0.25.  
 $e_d$  = saturated vapor pressure at dew temperature (kPa)

Adjustment for cloudiness  $f$  factor may be estimated from:

$$f = 0.9 \frac{n}{N} + 0.1 \quad (3.24)$$

Where  $n/N$  = ratio of actual to possible hours of sunshine

Note that for general purposes when only sunshine hours, temperature, and humidity data are available, net radiation ( $\text{MJ m}^2 \text{ day}^{-1}$ ) can be estimated by the following equation:

$$R_n = (1 - \alpha)(0.35 + 0.61 \frac{n}{N})S_o - (0.9 \frac{n}{N} + 0.1)(0.34 - 0.14\sqrt{e_d}) \sigma T^4 \quad (3.25)$$

Where:

$R_n$  = Net radiation ( $\text{MJ m}^2 \text{ day}^{-1}$ )

$\alpha$  = albedo from Table 3.1

$n/N$  = ratio of actual to possible hours of sunshine

$S_o$  = mean solar radiation from cloudless sky from Table 3.2 ( $\text{MJ m}^2 \text{ day}^{-1}$ )

$e_d$  = saturated vapor pressure at dew temperature (kPa)

$\sigma$  = the Stefan Boltzmann constant =  $4.903 \times 10^{-9} \text{ MJ m}^{-2} \text{ day}^{-1} \text{ K}^{-4}$

$T$  = the absolute air temperature of the evaporating surface in degrees Kelvin ( $^{\circ}\text{C} + 273$ )

$R_n$  can be expressed as an equivalent depth of evaporated water in mm by dividing  $R_n$  by  $\rho_w \lambda$ , where  $\rho_w$  ( $\text{kg/m}^3$ ) and  $\lambda$  ( $\text{MJ/kg}$ ).

### 3.3.2. Aerodynamic method

Besides the supply of heat energy, the second factor controlling the evaporation rate from an open water surface is the ability to transport water vapor away from the evaporative surface. The transport rate is governed by the humidity gradient in the air near the surface and the wind speed across the surface. The equation for aerodynamic method is

$$E_a = B ( e_{as} - e_a )$$

where (3.26)

$$B = \frac{0.622 k^2 \rho_a u_2}{p \rho_w [ \ln( z_2 / z_0 ) ]^2}$$

Where:

$E_a$  = Evaporation estimated by aerodynamic method (m/s)

(multiply by [1000 mm/m \*86400 s /day] to get in mm/day)

$e_s$  = saturation vapor pressure at the ambient temperature T (Pa)

$e_a = e_d$  = actual vapor pressure estimated using dew point temperature  $T_d$  or by multiplying  $e_s$  by the relative humidity  $R_h$  (Pa)

$B$  = the vapor transfer coefficient ( $m Pa^{-1} s^{-1}$ )

$k$  = the Von Karman constant = 0.4

$u_2$  = the wind velocity (m/s) measured at height  $z_2$  (cm) and  $z_0$  is from Table 3.3

$\rho_a$  = density of moist air ( $kg/m^3$ )

$\rho_w$  = density of water ( $kg/m^3$ )

$p$  = atmospheric pressure in Pa

**Table 3.3** A proximate values of the roughness height of natural surface.

Surface	Roughness height $Z_0$ (cm)
ice, mud flats	0.001
water	0.01-0.06
Grass (up to 10 cm high)	0.1 - 2.0.
Grass (10 -50 cm high)	2 -5
vegetation (1 - 2 m high)	20
trees ( 10-15 m high )	40-70

**Example3.3** Calculate the evaporation rate from open water surface by the aerodynamic method with air temperature 25°C, the relative humidity 40 %, air pressure 101.3 kPa, and wind speed 3 m/s, all measured at height 2m above the water surface. Assume a roughness height  $z_0 = 0.03$  cm.

**Solution:** The vapor transfer coefficient  $B$  is calculated using  $k = 0.4$ ,  $\rho_a = 1.19$  kg/m<sup>3</sup> for air at 25°C, and density of water 997 kg/m<sup>3</sup>.

$$\begin{aligned}
 B &= \frac{0.622 k^2 \rho_a u_2}{p \rho_w [\ln(z_2 / z_0)]^2} \\
 &= \frac{0.622 * 0.4^2 * 1.19 * 3}{101.3 * 10^3 * 997 * [\ln(2/3 * 10^{-4})]^2} \\
 &= 4.54 * 10^{-11} \text{ m/(Pa.s)}
 \end{aligned}$$

The evaporation rate is given by

$$E_a = B(e_{as} - e_a)$$

at 25°C,  $e_s = 3167$  Pa and  $e_a = R_h e_{as} = 0.4 * 3167 = 1267$  Pa

$$E_a = 4.54 * 10^{-11} (3167 - 1267) = 8.62 * 10^{-8} \text{ m/s}$$

$$= 8.62 * 10^{-8} * (1000 \text{ mm/m})(86400 \text{ s /day})$$

$$E_a = 7.45 \text{ mm/day}$$

### 3.3.3. Combined aerodynamic and energy balance method - the combination method:

Evaporation may be computed by the aerodynamic method when energy supply is not limiting and by the energy balance method when vapor transport is not limiting. But, normally both of these factors are limiting, so a combination of the two methods is needed. It is given by:

$$E = \frac{\Delta}{\Delta + \gamma} E_r + \frac{\gamma}{\Delta + \gamma} E_a \quad (3.27)$$

where:

$\Delta$  = the gradient of the saturated vapor pressure curve at air temperature =  $de_s/dT$ ,

$$\Delta = \frac{4098 e_{as}}{(237.3 + T)^2} \quad (3.28)$$

(Pa/°C) and is

$$\gamma = 66.8 \text{ (Pa / °C)}, \text{ psychrometric constant,}$$

$E_r$  and  $E_a$  = evaporation rate calculated based on energy balance, and aerodynamic methods respectively (mm/day).

**Example 3.5** Use the combination method to calculate the evaporation rate from an open surface subject to net radiation of 200 W/m<sup>2</sup>, air temperature 25 °C, relative humidity 40%, and wind speed 3 m/s, all recorded at height 2m, and atmospheric pressure 101.3 kPa.

**Solution:** The evaporation rate corresponding to net radiation of 200 W/m<sup>2</sup> is  $E_r = 7.10$  mm/day, and for the aerodynamic method is yields  $E_a = 7.45$  mm/day. The combination

$$= \frac{1005 * 1. * 101.3 * 10^3}{0.622 * 2441 * 10^3} = 67.1 \text{ Pa/°C}$$

method requires values for  $\gamma$  and  $\Delta$ .

$$\gamma = \frac{C_p K_h P}{0.622 l_v K_w}, \quad \frac{K_h}{K_w} = 1.00, \quad C_p = 1005 \text{ J/kg.K for air}$$

$\Delta$  the gradient of the saturated vapor pressure curve at 25°C with  $e_{as} = 3167$  Pa for T 25°C

$$\Delta = \frac{4098 e_s}{(237.3 + T)^2} = \frac{4098 * 3167}{(237.3 + 25)^2} = 187.7 \text{ Pa/}^\circ\text{C}$$

$$E = \frac{\Delta}{\Delta + \gamma} E_r + \frac{\gamma}{\Delta + \gamma} E_a,$$

$$= \frac{1887.7}{887.7 + 67.1} * 7.10 + \frac{67.1}{188.7 + 67.1} * 7.45 = 7.2 \text{ mm/day}$$

### 3.4 Evapotranspiration

Evapotranspiration is the combination of evaporation from the soil surface and transpiration from vegetation. The same factors governing open water evaporation also govern evapotranspiration, namely energy supply and vapor transport. In addition, a third factor enters the picture: the supply of moisture at the evaporative surface. As the soil dries out, the rate of evapotranspiration drops below the level it would have maintained in a well watered soil.

The combination method will give good estimate of reference crop evapotranspiration that is for the rate of evapotranspiration from an extensive surface of 8 cm to 15 cm tall green grass cover uniform height, actively growing, completely shading the ground and not short of water.

The potential evapotranspiration of another crop growing under the same conditions as the *reference crop*\* is calculated by multiplying the reference crop evapotranspiration  $E_r$  by *crop coefficient*  $k_c$ , the value of which changes with the stage of growth of the crop. The actual evapotranspiration  $E_t$  is found by multiplying the potential evapotranspiration by a *soil coefficient*  $k_s$  ( $0 < k_s < 1$ ).  $E_t = k_s k_c E_r$ . The values of the crop coefficient  $K_C$  vary over a range of about ( $0.2 < k_c < 1.3$ ).



Note that reference crop evapotranspiration  $E_{tr}$  can also be estimated by Penman-Monteith method:

$$E_{tr} = \frac{0.408\Delta(R_n - G) + \gamma \frac{900}{T + 273} U_2 (e_s - e_a)}{\Delta + \gamma(1 + 0.34U_2)} \quad (3.29)$$

where:

- $E_{tr}$  = reference crop evaporation (mm/day)
- $R_n$  = net radiation at crop surface (MJ/m<sup>2</sup>/d)
- $G$  = soil heat flux (MJ/m<sup>2</sup>/d)
- $T$  = average temperature (°C)
- $U_2$  = wind speed measured at 2 m height (m/s)
- $(e_s - e_a)$  = vapor pressure deficit (kPa)
- $\Delta$  = slope of vapor pressure curve (kPa/°C)  $\gamma$  = hygrometric constant (kPa/°C)
- $G$  = 0.4 (T<sub>month n</sub> mean temperature °C - T<sub>month n-1</sub> mean temperature °C)
- 900 = conversion factor

Sometimes  $E_{tr}$  is called PET (potential evapotranspiration) although this often refers to the evapotranspiration of a specific crop. Open water evaporation from reservoirs may be estimated by multiplying  $E_{tr}$  by a factor of 1.2. Estimated monthly PET over the Tekeze, Awash and Rift Valley, Abay, Dedisa and Dabus, Wabi Shebele and Genale Dawa, Omo Gibe, and Baro akobo are given in Annex 3.1.

### 3.5. Analysis of the homogeneity of meteorological data series

Weather data collected at a given weather station during a period of several years may be not homogeneous, i.e., the data set representing a particular weather variable may present a sudden change in its mean and variance in relation to the original values. This phenomenon may occur due to several causes, some of which are related to changes in instrumentation and observation practices, and others which relate to modification of the environmental conditions of the site, such as rapid urbanization or, on the contrary, perhaps development of irrigation in the area.

Changes relative to data collection may be caused by:

- i. change in type of sensor or instrument;
- ii. change in the observer and or change in the timing of observations;
- iii. "sleeping" data collector;
- iv. deterioration of sensors, such as with some types of pyranometers and RH sensors, or mal-functioning of mechanical parts, such as with a tipping bucket rain gauge, or by an intermittently broken or snorted wire;
- v. aging of bearings on anemometers;
- vi. use of incorrect calibration coefficients;
- vii. variation in power supply or electronic behavior of instruments;
- viii. growth of trees or planting of tall crops or construction of buildings or fences near a raingauge, anemometer, or evaporation pan;
- ix. change in the location of the weather station, or in the types of shelters for housing temperature and humidity sensors;
- x. change in the watering, type or maintenance of vegetation in the vicinity of the weather station;
- xi. significant change in the watering or type of vegetation of the region surrounding the weather station.

These changes cause observations made prior to the change to belong to a statistically different population than data collected after the change. It is therefore necessary to apply appropriate techniques to evaluate whether a given data set can be considered to be homogeneous and, if not, to introduce the appropriate corrections. To do so requires the identification of which sub-data series is to be corrected. To do this requires local information. Crop evapotranspiration - Guidelines for computing crop water requirements - FAO Irrigation and drainage paper **56** procedures are used in practice to check homogeneity of the data (<http://www.fao.org/docrep/X0490E>).

### 3.6 Practice Problems

3.1 The following mean meteorological data are obtained at an altitude of 2457 m amsl in the northern part of Ethiopia. Calculate the reference crop evapotranspiration by (a) the combination method and (b) the Penman Monteith method.

Month	Min Temp. °C	Max. Temp. °C	Humidity %	Wind at 2m km/day	Net radiation MJ/m <sup>2</sup> /day
Jan	4.9	24.1	56	130	21.5
June	9.2	26.9	38	164	25.8
July	10.7	23.3	54	156	21.7
August	9.8	22.8	72	156	21.6

December min and max temperature are 4.2 and 23 °C. May min and max temperature are 9.4 and 25.8 °C. Assume p at sea level is 102 kPa for the average temperature of 28 °C.

3.2 Use the combination method to calculate the evaporation rate from an open surface subject to net radiation of 220 W/m<sup>2</sup>, air temperature 20 °C, relative humidity 65%, and wind speed 4 m/s, all recorded at height 2m, and atmospheric pressure 102.3 kPa.

3.3 If a dam is constructed in the climatic area described in Problem 1, determine evaporation loss (million m<sup>3</sup>) in Jan, June, July and August. Take the average reservoir area as 150 km<sup>2</sup>.

3.4 Estimate actual evapotranspiration for cotton in mid season stage in April at Amibara, Ethiopia. Mean maximum temperature = 36 °C, mean minimum temperature = 22 °C, mean dew point temperature = 9 °C, mean wind speed = 1.5 m/s, mean percentage of possible sunshine = 94 %, elevation = 300 m, and assume G = 0.0.

3.5 Calculate the daily evaporation rate from an open water surface under the following climatic condition: incident radiation is 250 W/m<sup>2</sup>, mean air temperature is 35 °C, mean relative humidity is 35 %, mean wind speed is 1.5 m/s, mean density of air is 1.0 kg/m<sup>3</sup>, air pressure is 100 kPa, all measured at 2 m height. Furthermore, the roughness height of water is 0.03, the albedo of water is 0.09, the emissivity of water is 0.97, Stefan Boltzmann constant is  $5.67 \times 10^{-8} \text{ W}/(\text{m}^2 \cdot \text{K}^4)$ .